

NEW



SWIVELING UNIT RSP-FLEX

Smooth and precise swiveling

RÖHM
driven by technology

SWIVELING UNIT RSP-FLEX

Especially with automated loading and unloading of machine tools, the RSP-Flex swivel units offer an alternative to expensive special constructions. Due to the modular design and extensive expansion options they are flexible and securely integratable.

A significant increase in productivity is achieved by RÖHM swivel units RSP-Flex. This modular system meets the requirements of customized solutions with a high degree of flexibility. This provides a great range of applications - from loading and unloading crankshafts in machining centers to rapid and precise insertion of components in assembly systems. The powerful rotary motion and the precise pivot angle guarantee a constant output with reliable quality.

The perfect addition is the large gripper program of RÖHM - for every application the right solution. The modular design and expandability with pneumatic and electric feed-through of the swivel units RSP-Flex ensure optimal integration with minimal interference contour. Completed by the extensive possibilities for sensor monitoring the swivel units can be reliably implemented in the system.

BENEFITS AT A GLANCE

SMOOTH AND PRECISE SWIVELING

- ⊕ Innovative damper concept with flexible and infinitely variable adjustability in all end positions
- ⊕ Safety lock for end positions without loss of accuracy

FASTER CYCLE TIMES

- ⊕ High torque due to increased piston diameter
- ⊕ Reduced cycle time due to eliminating time of waiting by sensor recognition of the piston position with magnetic sensors

INCREASED PROCESS RELIABILITY

- ⊕ Maintenance free up to 10 million cycles
 - ⊕ Easy integration and programming by predefined S7 programming module
-

FUNCTIONAL PRINCIPLE AND APPLICATIONS

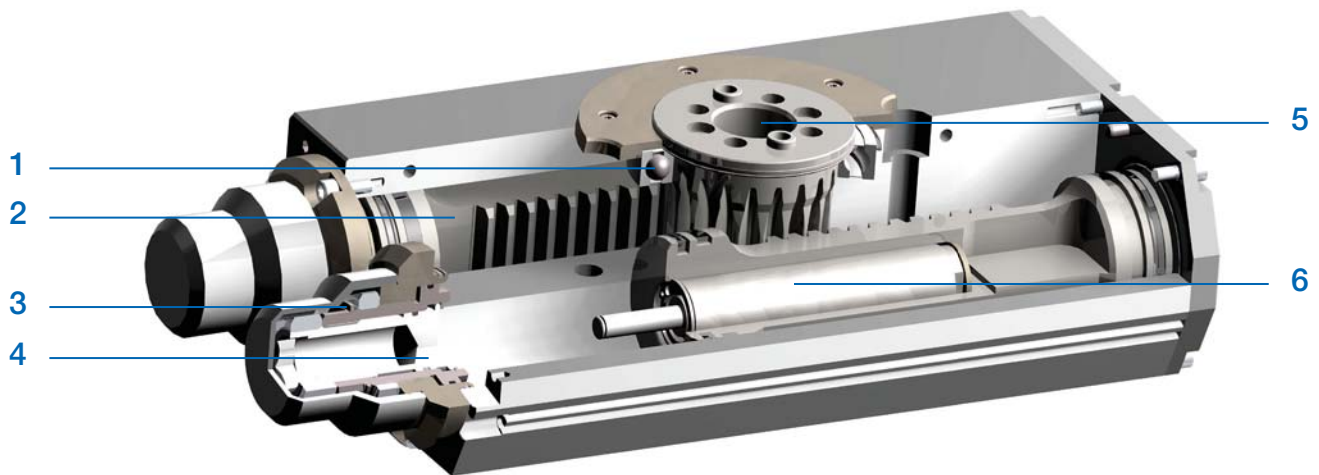

- 1 Strong dimensioned ball bearing for high load capacity
- 2 Double driven pneumatic cylinders
- 3 Finely graduated end position adjustment without loss of accuracy

- 4 Flexible adjustable damper adjustment
- 5 Big hole for media feed-through
- 6 Wear free high precision damper with high impact load capability



MODULAR DESIGN

Due to integrated media feed-through for pneumatic and sensoric cables there are manifold possibilities for application specific set-ups.



FROM A SINGLE SOURCE

With a large range of grippers the swivel units RSP-Flex can be expanded for each swiveling and gripping task. Everything from a single source - RÖHM.

MODULAR CONSTRUCTION FOR MAXIMUM FLEXIBILITY



RSP-Flex - basic unit*

- With through-hole



RSP-Flex - basic unit with fluid feed-through*

- With fluid feed-through and through-hole
- **-F4** 4-fold fluid feedthrough (RSP32-Flex)
- **-F8** 8-fold fluid feedthrough (RSP42-Flex / RSP52-Flex)



RSP-Flex - basic unit with fluid and cable feed-through*

- With fluid feed-through, with cable feed-through
- **-F4** + **-KD8** 8-fold cable feed-through (RSP32-Flex)
- **-F8** + **-KD8** 8-fold cable feed-through (RSP42-Flex / RSP52-Flex)



RSP-Flex - basic unit with fluid and cable feed-through and proximity switch adapter*

- With fluid feed-through, with cable feed-through, with proximity switch adapter to monitor the swivel position
- **-F4** + **-KD8** + **-AS** proximity switch adapter (RSP32-Flex)
- **-F8** + **-KD8** + **-AS** proximity switch adapter (RSP42-Flex / RSP52-Flex)

* for all swivel units it is recommended to monitor the swivel position with up to 6 magnetic field sensors

PIVOT ANGLE AND END POSITION ADJUSTABILITY

RSP-90-J3

Pivot angle 90°
End positions ± 3°

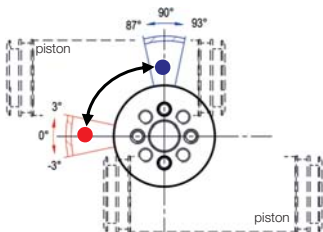

RSP-180-J3

Pivot angle 180°
End positions ± 3°

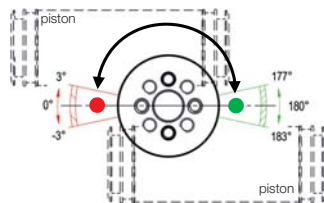

RSP-180-J90

Pivot angle 180°
End positions 90° ± 3°

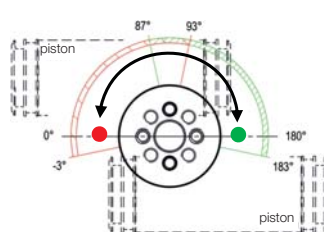

RSP-180-J3-MV

Pivot angle 90°-180°- 90°
End positions ± 3°

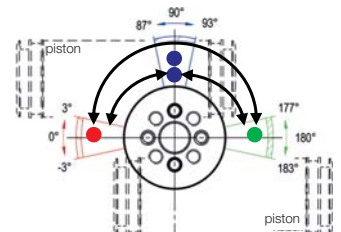

with mechanical mid-position locking

NEW TECHNOLOGIES

RSP-END POSITION ADJUSTMENT

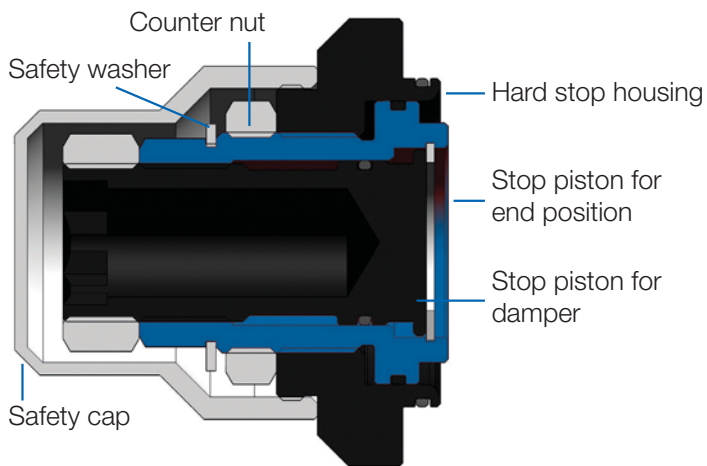

- ⊕ No loss of the end position because of strong safety lock
- ⊕ Stepless adjustment of the end angle
- ⊕ No loss of end position in case of damper adjustment

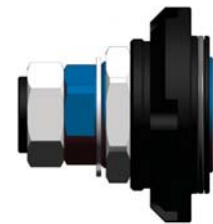

1. step: disassemble safety cap and loosen counter nut

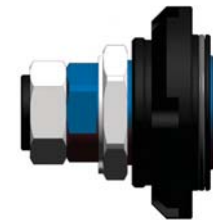

2. step: adjust end position

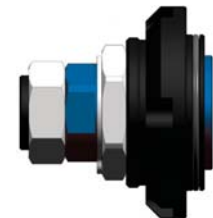

3. step: tighten counter nut and reassemble safety cap

THE DAMPER MAKES THE DIFFERENCE



Simple load adjustment

Flexible and easy damper setting from the outside with use of a key. The replacement or disassembly the swivel unit is not necessary. Result: fast and easy integration into the system.

The trick with the click

A unique feature is the ability to document the damper setting. By toggling the adjustment, specific settings can be reproduced quickly and safely.

SWIVELING UNIT RSP-FLEX

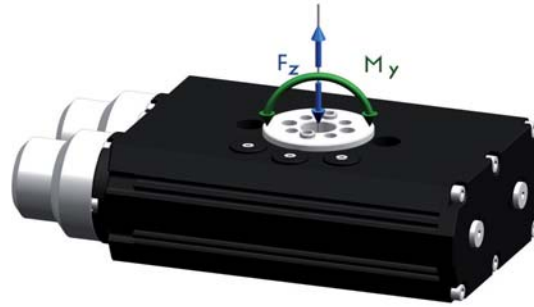

RSP-Flex 32, air operated

RSP32 basic unit	174000 RSP32-Flex-90-J3	174001 RSP32-Flex-180-J3	174002 RSP32-Flex-180-J90	174003 RSP32-Flex-180-J3-MV
RSP32 + fluid feed-through*	174006 RSP32-Flex-90-J3-F4	174007 RSP32-Flex-180-J3-F4	174008 RSP32-Flex-180-J90-F4	174009 RSP32-Flex-180-J3-MV-F4
RSP32 + fluid feed-through + cable feed-through**	174012 RSP32-Flex-90-J3-F4-KD8	174013 RSP32-Flex-180-J3-F4-KD8	174014 RSP32-Flex-180-J90-F4-KD8	174015 RSP32-Flex-180-J3-MV-F4-KD8
RSP32 + fluid feed-through + cable feed-through + proximity switch adapter***	174018 RSP32-Flex-90-J3-F4-KD8-AS	174019 RSP32-Flex-180-J3-F4-KD8-AS	174020 RSP32-Flex-180-J90-F4-KD8-AS	174021 RSP32-Flex-180-J3-MV-F4-KD8-AS
Pivot angle °	90	180	180	180 + 2x90
End position adjustability °	± 3	± 3	90 ± 3	± 3
Mid position adjustability °	-	-	-	± 3
Torque at 6 bar Nm	10	10	10	10
Nominal operating pressure bar (min./max.)	6	6	6	6
Connection hose-Ø mm	6	6	6	6
Operating temperature min./max. °C	5 - 80	5 - 80	5 - 80	5 - 80
Repeatability °	± 0,01	± 0,01	± 0,01	± 0,01
Weight kg	2,5	2,5	2,5	3,6
Axial bearing load F_z N	800	800	800	800
Radial bearing load M_y Nm	19	19	19	19

RSP-Flex 42, air operated

RSP42 basic unit	174024 RSP42-Flex-90-J3	174025 RSP42-Flex-180-J3	174026 RSP42-Flex-180-J90	174027 RSP42-Flex-180-J3-MV
RSP42 + fluid feed-through*	174030 RSP42-Flex-90-J3-F8	174031 RSP42-Flex-180-J3-F8	174032 RSP42-Flex-180-J90-F8	174033 RSP42-Flex-180-J3-MV-F8
RSP42 + fluid feed-through + cable feed-through**	174036 RSP42-Flex-90-J3-F8-KD8	174037 RSP42-Flex-180-J3-F8-KD8	174038 RSP42-Flex-180-J90-F8-KD8	174039 RSP42-Flex-180-J3-MV-F8-KD8
RSP42 + fluid feed through + cable feed-through + proximity switch adapter***	174042 RSP42-Flex-90-J3-F8-KD8-AS	174043 RSP42-Flex-180-J3-F8-KD8-AS	174044 RSP42-Flex-180-J90-F8-KD8-AS	174045 RSP42-Flex-180-J3-MV-F8-KD8-AS
Pivot angle °	90	180	180	180 + 2x90
End position adjustability °	± 3	± 3	90 ± 3	± 3
Mid position adjustability °	-	-	-	± 3
Torque at 6 bar Nm	23	23	23	23
Nominal operating pressure bar (min./max.)	6	6	6	6
Connection hose-Ø mm	6	6	6	6
Operating temperature min./max. °C	5 - 80	5 - 80	5 - 80	5 - 80
Repeatability °	± 0,01	± 0,01	± 0,01	± 0,01
Weight kg	5,0	5,0	5,0	7,1
Axial bearing load F_z N	2900	2900	2900	2900
Radial bearing load M_y Nm	68	68	68	68

* number of fluid feed-throughs RSP32=4; RSP42/RSP52=8 (max. 8 bar)

** number of signals=RSP32=8; RSP42/52=10 (24V, max. 1A), plug machine side M16, plug tool side M8

*** number of holders for proximity switches: 3

SWIVELING UNIT RSP-FLEX

RSP-Flex 52, air operated

RSP52 basic unit	174048 RSP52-Flex-90-J3	174049 RSP52-Flex-180-J3	174050 RSP52-Flex-180-J90	174051 RSP52-Flex-180-J3-MV
RSP52 + fluid feed-through*	174054 RSP52-Flex-90-J3-F8	174055 RSP52-Flex-180-J3-F8	174056 RSP52-Flex-180-J90-F8	174057 RSP52-Flex-180-J3-MV-F8
RSP52 + fluid feed-through + cable feed-through**	174060 RSP52-Flex-90-J3-F8-KD8	174061 RSP52-Flex-180-J3-F8-KD8	174062 RSP52-Flex-180-J90-F8-KD8	174063 RSP52-Flex-180-J3-MV-F8-KD8
RSP52 + fluid feed through + cable feed-through + proximity switch adapter***	174066 RSP52-Flex-90-J3-F8-KD8-AS	174067 RSP52-Flex-180-J3-F8-KD8-AS	174068 RSP52-Flex-180-J90-F8-KD8-AS	174069 RSP52-Flex-180-J3-MV-F8-KD8-AS
Pivot angle °	90	180	180	180 + 2x90
End position adjustability °	± 3	± 3	90 ± 3	± 3
Mid position adjustability °	-	-	-	± 3
Torque at 6 bar Nm	58	58	58	58
Nominal operating pressure bar (min./max.)	6	6	6	6
Connection hose-Ø mm	6	6	6	6
Operating temperature min./max. °C	5 - 80	5 - 80	5 - 80	5 - 80
Repeatability °	± 0,01	± 0,01	± 0,01	± 0,01
Weight kg	10,2	10,2	10,2	13,9
Axial bearing load F_z N	9000	9000	9000	9000
Radial bearing load M_y Nm	340	340	340	340

Accessories

Magnetic sensor complete with holder	Id.-No.	Design	For
	1276722	3m cable, 3 litz wire	all sizes, all types
	1276723	0,2m cable, M8x1 connector	all sizes, all types

Inductive adaptor kit proximity switch has to be ordered separately	Id.-No.	For
	171659	Size 32 basic unit
	172450	Size 32 basic unit with fluid feeder
	172453	Size 42 basic unit
	172439	Size 42 basic unit with fluid feeder
	172409	Size 52 basic unit
	172410	Size 52 basic unit with fluid feeder

Inductive proximity switch not included in the adaptor kit	Id.-No.	Design	For
	389661	3m cable, 3 litz wire	all sizes, all types
	1078808	0,2m cable, M8x1 connector	all sizes, all types
	680969	without cable, M8x1 connector	all sizes, all types

SWIVELING TIME DIAGRAMS

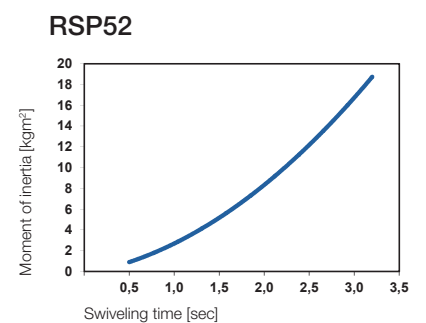
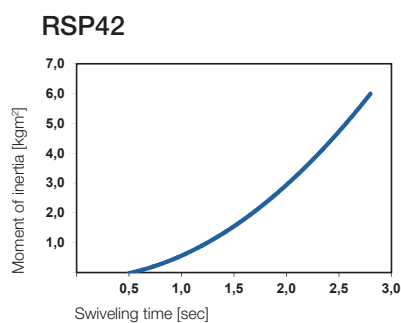
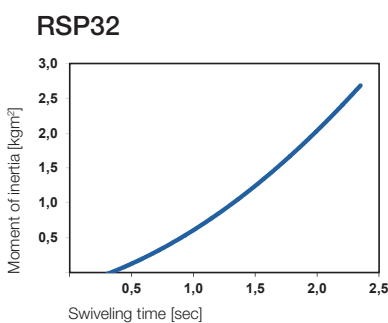

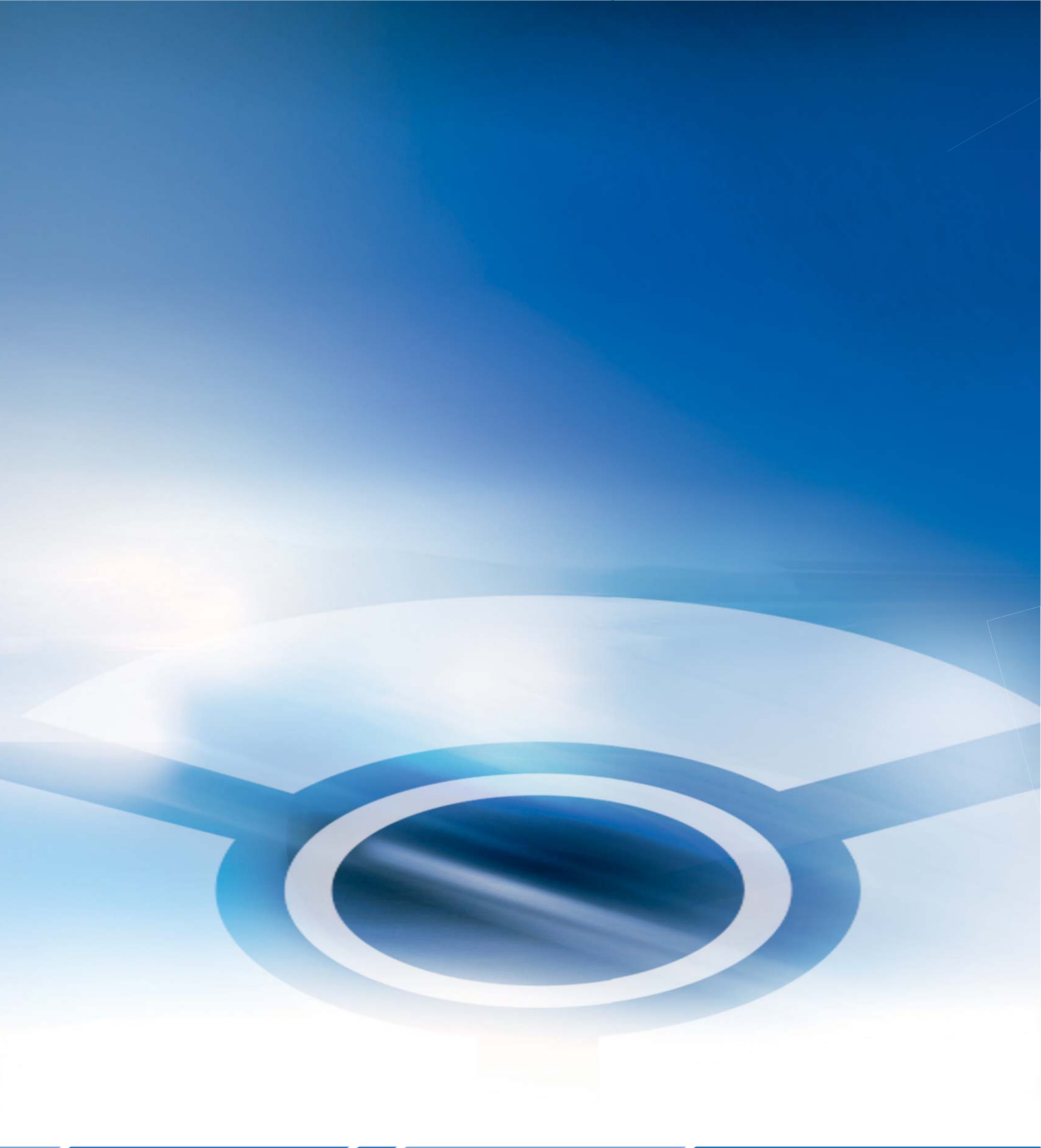

RÖHM GmbH

Heinrich-Röhm-Straße 50

89567 Sontheim/Brenz

Germany

Tel +49 7325 16 0

Fax +49 7325 16 510

info@roehm.biz

www.roehm.biz



Id.-No. 1242308 / 1115