

PROMOTION

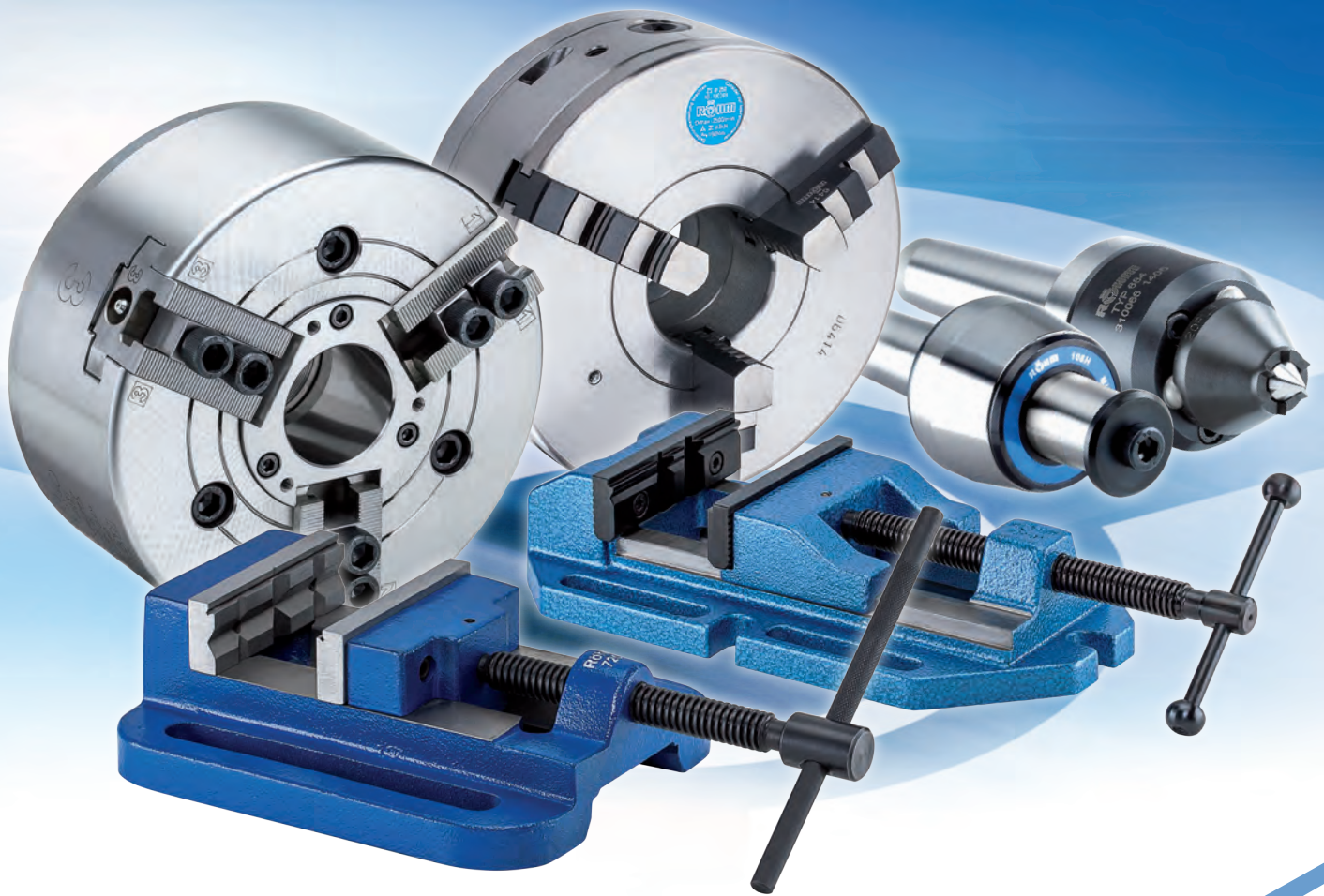

RÖHM STEEL ICONS 2017-2

Valid until 30. September 2017

RÖHM
driven by technology

MZK

Revolving centering taper MZK



APPLICATION

For counter-clamping workpieces with large boreholes, such as pipes on lathes and grinding machines.

TYPE

With interchangeable centering taper attachments. Optionally with draw-off nut or fixed shaft.

CUSTOMER BENEFITS

- ② High flexibility thanks to interchangeable centering taper attachments
- ② Quick change of interchangeable centering taper attachments

TECHNICAL FEATURES

- Body hardened and ground
- Centering taper inserts hardened and ground

A06
Revolving centering taper

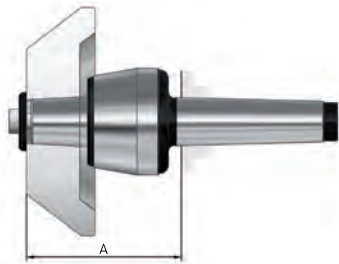

Item no.	Size	Mount MT	A mm	Workpiece weight max. kg	Concentricity deviation max. mm	Speed max. min ⁻¹	Weight g	Gross Price	Promotion Price
304562	108	4	103	800	0,005	3800	2200	411.00 €	350.00 €
304563	110	5	128	1600	0,005	3000	4800	595.00 €	505.00 €
304564	114	6	159	3000	0,005	2600	12000	1,190.00 €	1,010.00 €

With fastening screw and disc, without centering taper attachment



Buy online now:
Revolving centering taper

A06
Revolving centering tapers with **draw-off nut**, for high load

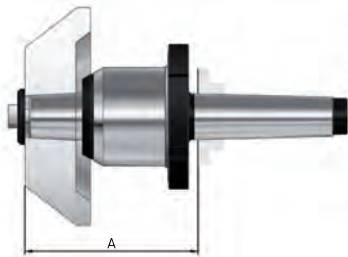

Item no.	Size	Mount MT	A mm	Workpiece weight max. kg	Concentricity deviation max. mm	Speed max. min ⁻¹	Weight g	Gross Price	Promotion Price
304583	494	4	118	1000	0,005	7000	3200	976.00 €	830.00 €
304584	495	5	140	2000	0,005	6000	6500	1,500.00 €	1,275.00 €
304585	496	6	168	3500	0,005	4800	13500	2,690.00 €	2,285.00 €

With fastening screw and disc, without centering taper attachment



Buy online now:
Revolving centering taper with draw-off nut

A07
Fixed shaft



Item no.	Mount MT	A mm	Workpiece weight max. kg	Concentricity deviation max. mm	Weight g	Gross Price	Promotion Price
304580	4	45	2000	0,003	800	137.00 €	115.00 €
304581	5	60	4800	0,003	2000	199.00 €	170.00 €
304582	6	70	12000	0,003	5500	398.00 €	340.00 €

With fastening screw and disc, without centering taper attachment



Buy online now:
Revolving centering taper with fixed shaft

MZK

A06
Suitable **inserts AZ** for centering tapers, standard version, taper 75°



Item no.	Size	for MT	B mm	C mm	D mm	E mm	Weight g	Gross Price	Promotion Price
304565 ¹⁾	1	4	60	68	5	32	900	155.00 €	130.00 €
304566	2	4	100	45	45	32	1500	232.00 €	195.00 €
304567	3	4	150	45	95	32	4100	348.00 €	295.00 €
304568	4	4	200	45	145	32	6000	522.00 €	445.00 €
304569	5	4	250	45	195	32	8500	784.00 €	665.00 €
304570	1	5	100	43	45	40	1500	278.00 €	235.00 €
304571	2	5	150	43	95	40	4400	417.00 €	355.00 €
304572	3	5	200	43	145	40	6100	626.00 €	535.00 €
304573	4	5	250	43	195	40	8100	939.00 €	800.00 €
304574	5	5	300	43	245	40	11600	1,410.00 €	1,200.00 €
304575	1	6	150	54	95	50	3000	501.00 €	425.00 €
304576	2	6	200	54	145	50	8100	751.00 €	640.00 €
304577	3	6	250	54	195	50	11100	1,130.00 €	960.00 €
304578	4	6	300	54	245	50	14000	1,690.00 €	1,435.00 €
304579	5	6	350	54	295	50	18800	2,540.00 €	2,160.00 €

¹⁾ Without fixing by screw and washer

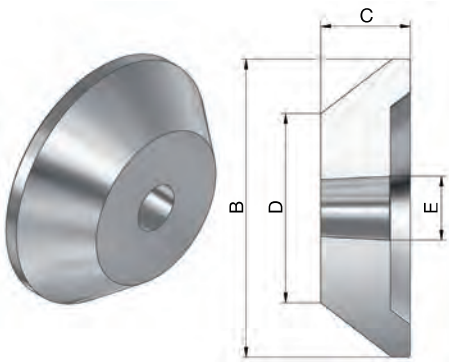

Buy online now:
Inserts for centering tapers

CoE - Assortment

Constant face drivers
CoE



APPLICATION

For the rational **turning and milling** of workpieces on its entire length without reclamping with max. precision.

TYPE

Basic body with morse taper and mechanical pressure compensation.
Clamping circuit \varnothing 8-80 mm.
Workpiece weight max. 100 kg.

CUSTOMER BENEFITS

- ⊕ For **turning and milling** in one set-up
- ⊕ Compensating driving disc, radially backlash-free
- ⊕ Maximum concentricity of up to 0.01 mm
- ⊕ Stable and constant workpiece length stop on the front side thanks to resilient centre point
- ⊕ Maximum flexibility thanks to universal exchange of driving disc and centre point

TECHNICAL FEATURES

- Guide value for axially permissible total load on 3 support pistons: 9000 N

A14

CoE small assortment in wooden box, mechanical pressure compensation, clamping circuit \varnothing 12-50, turning range 13-100 mm



Item no.	MT	Weight approx. g	Gross Price	Promotion Price
1209048	3	3600	+085.00 €	925.00 €
1209049	4	3870	+115.00 €	945.00 €
1209050	5	4550	+165.00 €	990.00 €



Buy online now:
CoE assortment

Included in delivery:

- 1x basic body
- 4x driving discs (clamping circuit \varnothing 12, 20, 32, 50)
- 3x centre points (centering \varnothing 6, 12, 16)

A14

Mounting sleeve for clamping the face driver in the lathe chuck

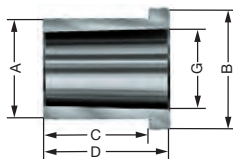

Item no.	MT inside	A mm	B mm	C mm	D mm	G mm	Gross Price	Promotion Price
085033	3	32	39	32	40	23,825	87.60 €	74.00 €
085034	4	40	47	42	50	31,267	97.90 €	83.00 €
085035	5	55	62	52	60	44,399	129.00 €	110.00 €



Buy online now:
Mounting sleeve

ZS Hi-Tru - with radial fine adjustment



APPLICATION

Optimized for machining workpieces which must be produced with maximum concentricity. Can be universally used, but is especially advantageous on turning and grinding machines as well as dividing units.

TYPE

Lathe and grinding chuck in steel design, with which the workpiece can be adjusted very sensitively to the desired concentricity via 3 tangentially arranged adjusting spindles.

CUSTOMER BENEFITS

- ⊕ Radial fine adjustment for maximum concentricity
- ⊕ Repeatability 0.015 mm
- ⊕ Adjusting accuracy within 0.005 mm
- ⊕ Precision adjustment without opening the mounting screws
- ⊕ Jaws in chuck ground out for concentricity

TECHNICAL FEATURES

- With one set each of turning and drilling jaws
- Hardened adjusting spindles, as well as their support surfaces
- Hardened spiral ring
- Steel take-up flange

Lathe and grinding chucks ZS Hi-Tru

A09

ZS Hi-Tru, with one set outward stepped jaws and one set inward stepped jaws DIN 6350, cylindrical centre mount, Form A

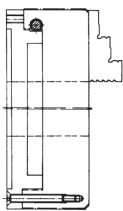

Item no.	Size	Cylindrical centre mount mm	Through-hole mm	Speed max. min ⁻¹	Torque Nm	Total clamping force kN	Gross Price	Promotion Price
180259	80	56	19	7000	30	13	686.00-€	585.00 €
180261	100	70	20	6300	60	27	746.00-€	635.00 €
180263	125	95	32	5500	80	31	931.00-€	790.00 €
180265	160	125	42	4600	110	47	1,195.00-€	1,015.00 €
180267	200	160	55	4000	140	55	1,570.00-€	1,335.00 €
180269	250	200	76	3000	150	63	2,050.00-€	1,745.00 €
180271	315	260	103	2300	180	69	3,050.00-€	2,590.00 €

On request from size 125 with 6 jaws or with short-taper mount to ISO 702-3 (DIN 55027) or ISO 702-2 (DIN 55029) Camlock
Further sizes and mountings available on request



Buy online now:
ZS Hi-Tru Lathe and grinding chuck

DIN 6350 Dimensions ZS Hi-Tru, cylindrical centre mount, Form A

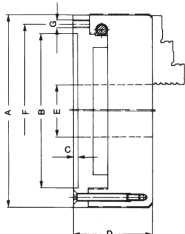

Size A	Zoll	B+0,02	C	D	F	G	Hexagon	Weight
ZS Hi-Tru, with one set outward stepped jaws and one set inward stepped jaws								
80	3 ^{1/4}	56	3	50,5	67	3xM6	4	1,7
100	4	70	3	63	83	3xM8	5	3,6
125	5	95	4	72	108	3xM8	5	5,6
160	6 ^{1/4}	125	4	81	140	3xM10	6	10
200	8	160	4	89,5	176	3xM10	6	17,2
250	10	200	5	102	224	3xM12	8	34,5
315	12 ^{1/2}	260	5	122	286	3xM16	8	57,5

Figure fine adjustment:

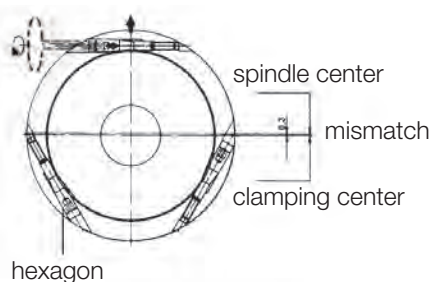

BOF



APPLICATION

For securely clamping workpieces on drills and measuring machines.

TYPE

Clamping system mechanical, manually operated.
Standard version.

CUSTOMER BENEFITS

- ⊕ Optimal price/performance ratio
- ⊕ Entire clamping range within reach by turning
- ⊕ Mounting possibilities on the side and frontal
- ⊕ Long guidance of moving jaw, even in the external clamping range
- ⊕ Clamping jaws are reversible, one side smooth and ground on both sides
- ⊕ Solid clamping jaw with one longitudinal prism and two transverse prisms
- ⊕ Both jaws with support surface for clamping flat workpieces

TECHNICAL FEATURES

- Body made out of special steel casting
- Low, stable design with thread spindle

A12
BOF, with V-jaw and normal jaw SBO

Item no.	Size	Jaw width mm	Clamping capacity mm	Jaw height mm	Length mm	Height mm	Length body mm	Weight kg	Gross Price	Promotion Price
111595	2	110	130	32	470	72,5	315	9,5	283,00 €	240.00 €
111596	3	135	160	40	550	80,5	365	13,5	345,00 €	295.00 €
111597	4	160	220	50	692	95,5	445	25	541,00 €	460.00 €



Buy online now:
BOF drilling machine vice

Drilling machine vices

BSH, sturdy craftsman design



APPLICATION

For securely clamping workpieces on drills and measuring machines.

TYPE

Sturdy version for drill stands, table drills and box column drills.
Clamping system mechanical, manually operated.

CUSTOMER BENEFITS

- ⊕ Long lever for maximal clamping force
- ⊕ Both jaws with support surface for clamping flat workpieces

TECHNICAL FEATURES

- Moving steel jaw is supported by a cast iron jaw with inner guidance
- Solid clamping jaw with three vertical prisms and one horizontal prism
- Jaws and spindle gunmetal-finished
- Body made out of cast metal
- Long mounting slots

A12
BSH, sturdy craftsman design

Item no.	Size	Jaw width mm	Clamping capacity mm	Length body mm	Width body mm	Height mm	Jaw height mm	Weight kg	Gross Price	Promotion Price
007197	4	80	80	200	140	70	40	5	64,40 €	55.00 €
007201	5	100	95	215	175	75	40	7	71,60 €	60.00 €
007202	6	120	110	260	215	85	40	11	90,10 €	75.00 €
007207	7	140	150	300	220	85	40	12,5	102,00 €	85.00 €



Buy online now:
BSH drilling machine vice

KFD-HE - 3-jaw, standard design



APPLICATION

Standard power chuck with through-hole for bar and tube machining, as well as for flange-type workpieces.

TYPE

Standard version with cylindrical centre mount.
3-jaw version with serration 90° and 60°.
Universal draw tube adapter at serration 60°.

CUSTOMER BENEFITS

- ⊕ Large through-hole for hollow or partially hollow clamping
- ⊕ Long-tested chuck principle for maximum service life
- ⊕ Delivery of the suitable draw tube adapter with through-hole within 7 working days

TECHNICAL FEATURES

- Power transmission by means of wedge hook principle
- Direct lubrication of all wear surfaces
- Sturdy chuck construction

SERRATION 90°: 3-jaw power chuck KFD-HE, cylindrical centre mount, mounting dimensions to DIN 6353

Item no.	154384	154031	154032	154829
Promotion Price	1,595.00 €	1,700.00 €	2,160.00 €	2,475.00 €
Gross Price	1,775.00 €	1,890.00 €	2,400.00 €	2,750.00 €
Size	170	210	254	315
Jaw travel B mm	3,2	4,3	5,1	5,3
C mm	82	93	101	114
DH6 / ZA mm	140 / 3 x M 10	170 / 3 x M 12	220 / 3 x M 16	300 / 3 x M 20
Wedge stroke K mm	14	16	19	23
Through-hole M mm	43	52	75	121
Q mm	M 52 x 1,5	M 58 x 1,5	M 82 x 1,5	M 126 x 1,5
Maximum draw bar pull kN	25	40	60	60
Max. total clamping force approx. kN	75	110	135	160
Max. admissible speed min ⁻¹	6300	5000	4500	3500
Moment of inertia J kgm ²	0,038	0,09	0,22	0,8
Weight without jaws approx. kg	12	18	29	50

SERRATION 60°: 3-jaw power chuck KFD-HE, cylindrical centre mount, mounting dimensions to DIN 6353

Item no.	154390	154391	154392	154830
Promotion Price	1,760.00 €	1,875.00 €	2,375.00 €	2,720.00 €
Gross Price	1,955.00 €	2,085.00 €	2,640.00 €	3,020.00 €
Size	170	210	254	315
Jaw travel B mm	3,4	4,3	5,1	5,3
C mm	82	93	101	114
DH6 / ZA mm	140 / 3 x M 10	170 / 3 x M 12	220 / 3 x M 16	300 / 3 x M 20
Wedge stroke K mm	14	16	19	23
Through-hole M mm	43	52	75	121
Q mm	M 53 x 1,5	M 60 x 2	M 85 x 2	M 130 x 2
Maximum draw bar pull kN	25	40	60	60
Max. total clamping force approx. kN	75	110	135	160
Max. admissible speed min ⁻¹	6300	5000	4500	3500
Moment of inertia J kgm ²	0,038	0,9	0,22	0,8
Weight without jaws approx. kg	12	18	29	50

To order the suitable draw tube adapter with through-hole (delivery within 7 working days), please send the completed draw tube adapter data sheet. This data sheet can be found in the RÖHM eShop at www.eshop.roehm.biz in the area KFD-HE.



Buy online now:
KFD-HE power chuck
serration 90°



Buy online now:
KFD-HE power chuck
serration 60°



RÖHM GmbH

Heinrich-Röhm-Straße 50

89567 Sontheim/Brenz

Germany

Tel +49 7325 16 0

Fax +49 7325 16 510

info@roehm.biz

www.roehm.biz

