



driven by technology

NEW GENERATION HSK CLAMPING SETS

Clip ring replaces vulcanized rubber



HSK CLAMPING SETS WITH CLIP RING

- ⌚ 27% shorter installation length for lower space requirement
- ⌚ 39% greater clamping force than required in as standard
- ⌚ Compact force flow for high system rigidity
- ⌚ Easy installation of clamping set

(Compared to the usual clamping sets of size HSK-A 63)

HSK CLAMPING SETS WITH CLIP RING

The proven RÖHM HSK clamping sets are further improved: the collet segments are connected with a replaceable clip ring, instead of vulcanized rubber as before. The collet segments can be quickly and easily clipped into the retaining ring during disassembly. This extends the life of the collet segments and provides significant cost savings.

ADVANTAGES AT A GLANCE

- Eliminates errors due to deteriorating vulcanization
- Easy to repair if the retaining ring becomes damaged
- Optimized opening operation of the clamping set
- Improved material properties

CLIP RING REPLACES VULCANIZED RUBBER

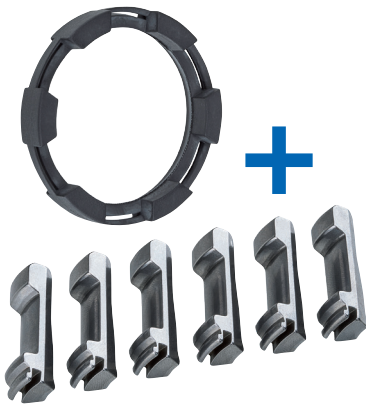

New: Clip ring and collet segments



Installation of collet segments



Collet with replaceable clip ring and pressure piece



Complete clamping set design: standard

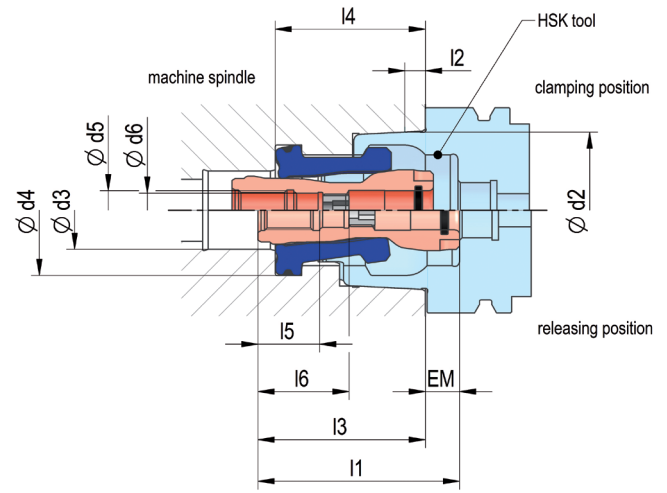

HSK CLAMPING SETS WITH CLIP RING

Design	Standard (RÖHM catalog page 8007)			High Speed (RÖHM catalog page 8008)		
Item No.	1037448	1037449	1037451	1037501	1015151	462324
Size HSK-A/C/E/T	50	63	100	50	63	100
Size HSK-B/D/F	63	80	125	63	80	125
Total stroke	15	14	18	15	14	18
Pull-out stroke AM	0,5	0,5	0,8	0,5	0,5	0,8
Taper-Ø	38	48	75	38	48	75
D3	18	24	40	18	24	40
D4	32	40	63	32	40	63
D5	M10x1	M12x1	M20x1,5	M10x1	M12x1	M20x1,5
D6	8	10,5	17,5	8	10,5	17,5
L1	50	62	98,5	50	62	98,5
L2	5	6,3	10	5	6,3	10
L3	39,5	51,5	85,2	39,5	51,5	85,2
L4	37,2	46,2	73	37,2	46,2	73
L5	17	19	34,5	17	19	34,5
L6	26	28	51	26	28	51
Adjusting size EM	10,5	10,5	13,3	10,5	10,5	13,3
Draw bar pull kN	3	4	10	3	4	10
Clamping force kN	15	25	50	15	25	50
Max. application speed min ⁻¹	36.000	24.000	14.000	50.000	40.000	24.000
Clipping (Item No.)	1330757	1297374	1330784	330757	1297374	1330784
Assembly tool (Item No.)	1329001	1324230	1329010	1329001	1324230	1329010

ASSEMBLY TOOL FOR HSK CLAMPING SETS

- ⊕ Significant time savings as assembly of the clamping sets only takes seconds
- ⊕ Prevents damage to the clamping set and spindle
- ⊕ User-friendly and reliable handling of the assembly tool

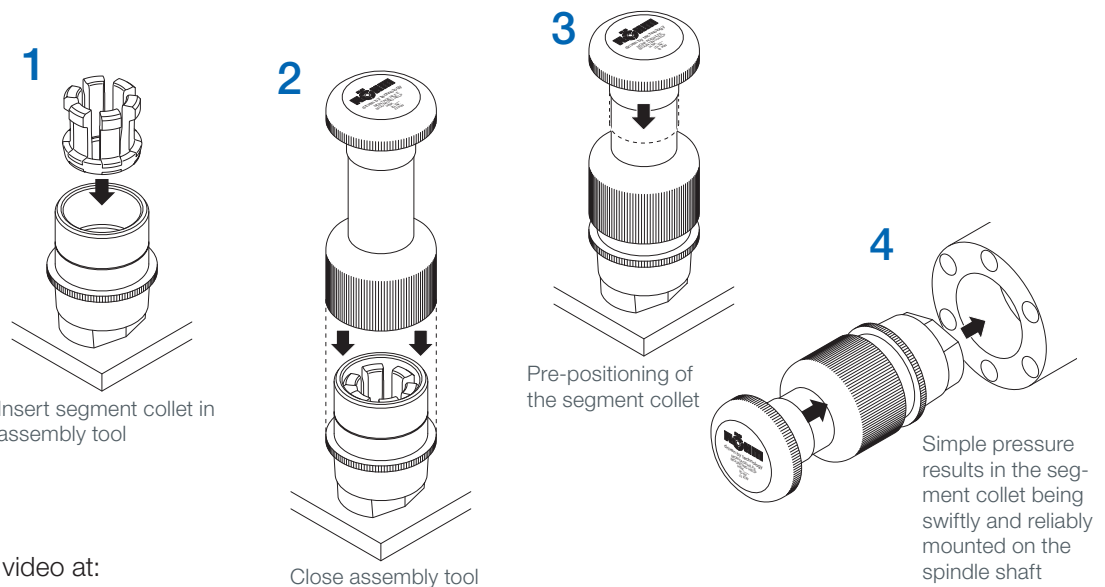

More information from the video at:
www.roehm.biz/assemblytool

RÖHM GmbH

Heinrich-Röhm-Straße 50

89567 Sontheim/Brenz

Germany

Tel +49 7325 16 0

Fax +49 7325 16 510

info@roehm.biz

www.roehm.biz



driven by technology